



Installation Guide

Simplicity 6

Tools Required

Below is a list of tools that you will require to install the Simplicity 6 Canopy or Carport.

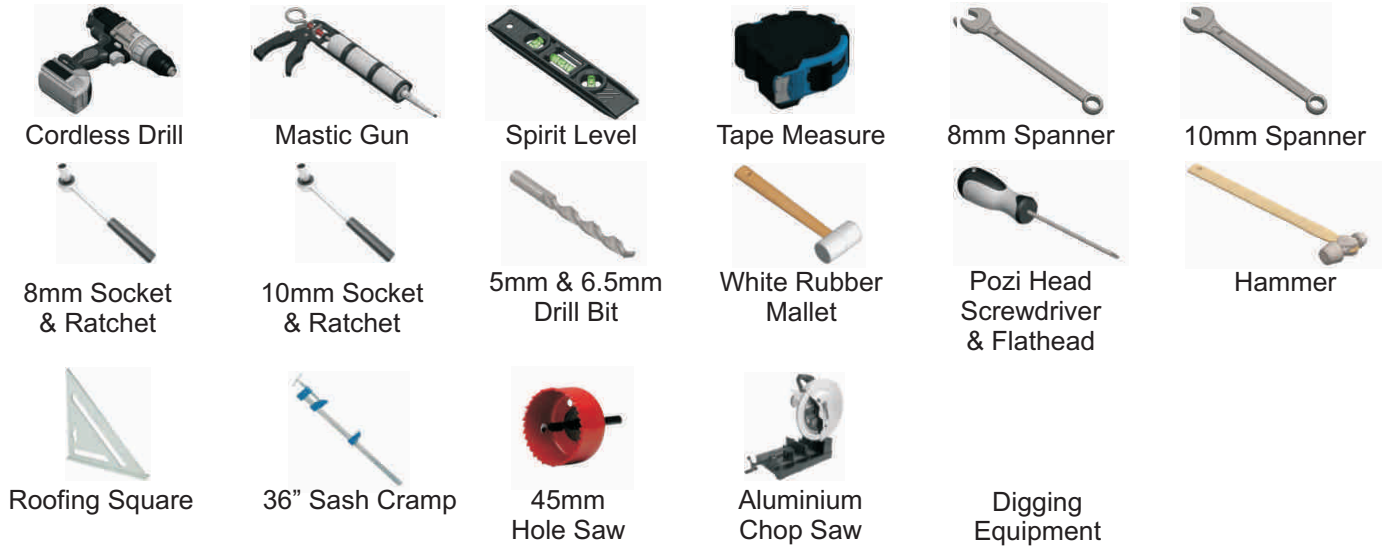

Materials **NOT** supplied with your system:

- Wall Plate Fixings ▪Bolt Down Post Fixings ▪Concrete or Material for 'making good' ▪Lead Flashing
- Patination Oil ▪Electrical Cable for LED Lighting connection ▪Cleaning Materials

Parts Supplied

Below is a list of the parts supplied with your new canopy. Please check that all parts are present before commencing the installation process.

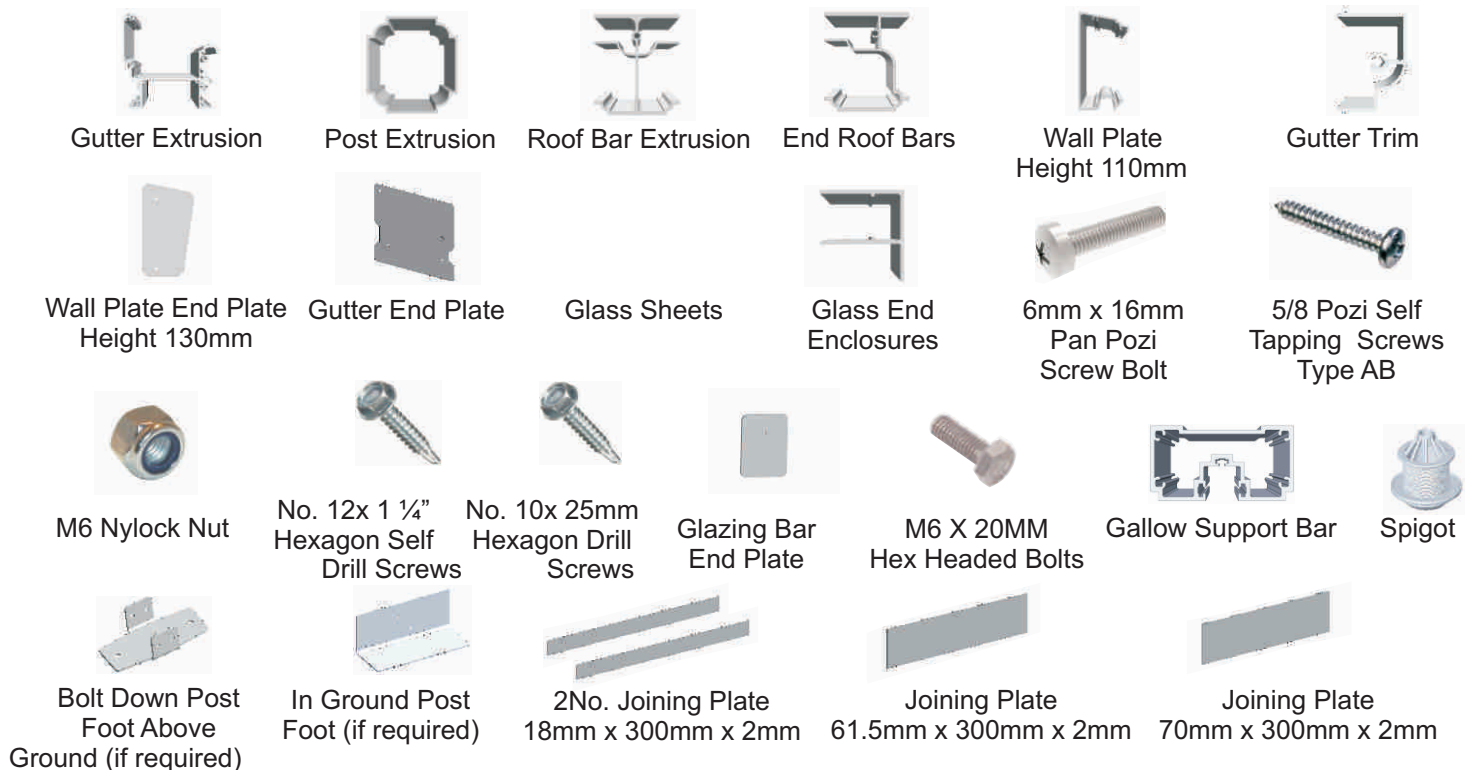

*Please refer to your CAD drawing for each individual order as this will show the roof bar spacing as per your order. This installation guide is generic and the centre's spacing is given as a guide example only.

Preliminary Stages and Planning

Before starting your install please check all components for quantity and damage.

Below is a roof span chart which you MUST refer to in order to establish the maximum centre to centre dimensions of your roof bars and posts.

SPAN Chart Roof Bars	Up to 3.2m Projection
System 6	600mm Roof Bar Spacings

POST SPACINGS	Up to & Including 3.2m Projection
System 6	3m Post Spacings

PLEASE NOTE – A MAXIMUM OF 500MM OVERHANG ON THE GUTTER IS ALLOWED

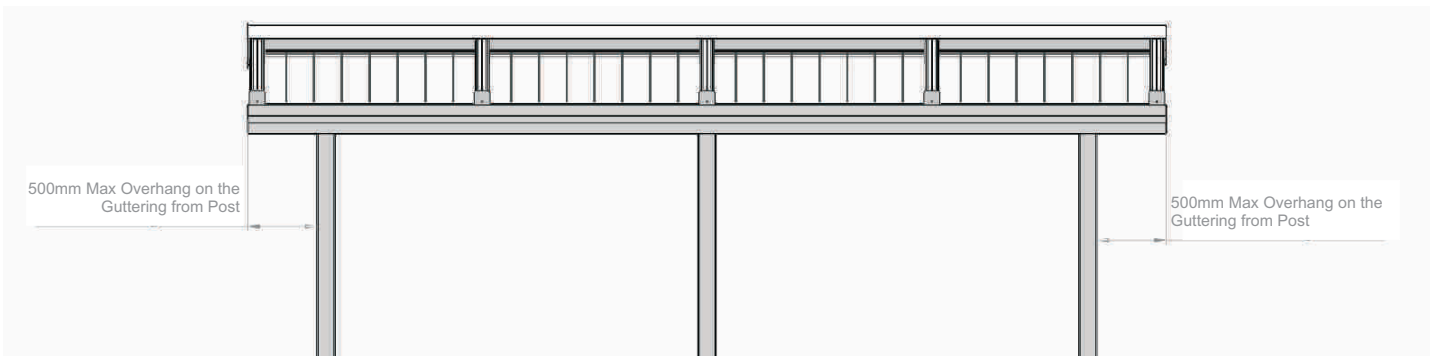

PLEASE NOTE, IF USING SELF CLEANING GLASS A MINIMUM PITCH OF 10° IS REQUIRED.

At 3.2 metres projection the maximum pitch of your roof system is 13° due to glass length, contact the office for further details.

Be aware! You must ensure all glass is installed with the film facing upwards (sky). This will ensure that if installing self cleaning glass it is the correct way up.

Please note when ordering Pilkington Self Cleaning Glass:

Pilkington Activ™ needs both daylight and rain to work effectively. When the roof angle gets too low the rain does not wash the loosened dirt off as effectively. A good flow of water across the glass is beneficial. Pilkington Activ™ still gives better results than ordinary glass with low angle roof applications. We recommend a minimum angle of 10 degrees.

You are now ready to start installing the structure, following all steps within this guide.

Lighting (if required)

The lighting consists of an aluminium extrusion that can fit to either the bottom of the wall plate, or the back of the gutter beam. When installing lighting please consider cable exist and cable entry to the light channel. The lighting also comes with an electrical capacitor for each 6m of light and an optional external grade plastic box to house the capacitors if the installation requires that they be mounted outside.

STEP 1

Foundation Hole Positions for Posts

Establish the height of the canopy/carport at the back (wall edge) and the height of the canopy at the front. The height at the front must be above 2.1m to meet the minimum legal head height requirement.

Once you have established your height at the front and back, deduct the height at the front from the height at the back to give you "The Fall" (x). Measure distance 'x' up the wall and position your roof bar at this height on the wall. Let the other end touch the ground and where that touches will be the centre of your hole for the foundation.

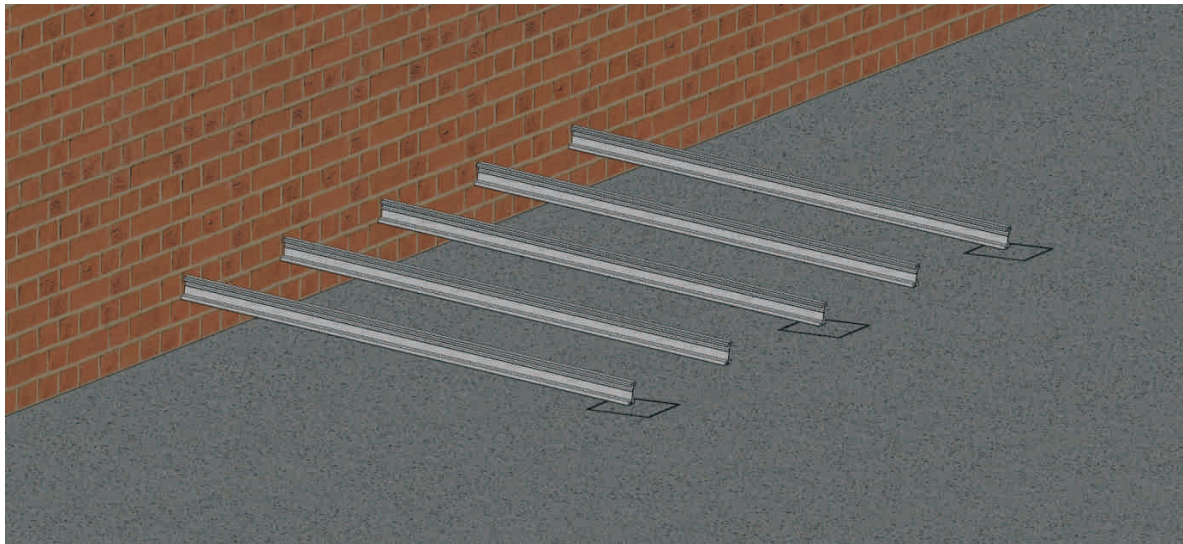

IMPORTANT: Use roofing square to ensure the bar used is held square to the wall.

STEP 2

Digging of Holes

You can either cast foundations first or dig holes for casting after. (Bolt to or cast in)

Holes or foundations must be a minimum of 300x300x600 deep. This is only a guide. Please consult a structural engineer for verification



STEP 3

Fitting of Wall Plate to the Wall

Measure 30mm in from one end of the Wall plate and approx 55mm down from the top of the inside profile and mark before you drill. Drill the wall plate using the correct sized drill bit for the suitable wall fixings that you intend to use (not supplied). Once this is done repeat at the other end. Continue to drill holes in the wall plate at approx 55mm down and at approx 300mm centres. This is only a guide. Please consult a structural engineer for verification. See diagram

You must ensure the wall plate is not twisted or bowed. Use a spirit level to make sure the wall plate is fitted level.

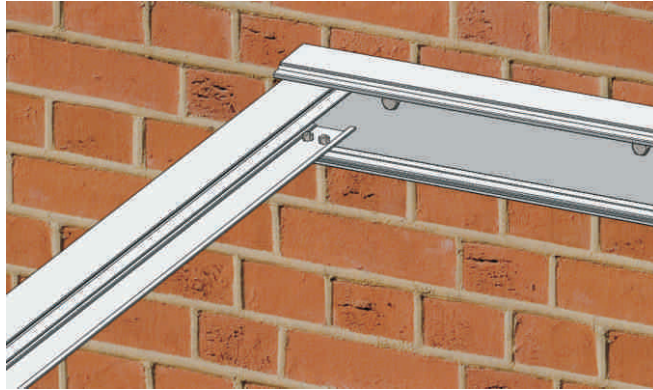

Using suitable wall fixings, fix the wall plate to the wall, we recommend plastic caps are fitted over the screw/bolt heads for aesthetic reasons.

STEP 4

Fitting of Post Feet to Posts

Centralise the post foot to the post and attach using 2 x No. 12 x 1 ¼" self drill screws **(Note the post foot is only suitable for surface mounting the posts. If your posts need to be concreted into the ground please follow step 4a overleaf)**

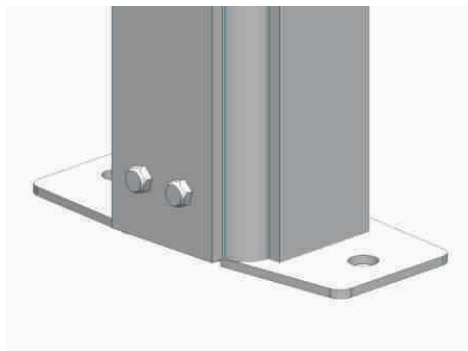

STEP 4a

Fitting of Post Feet to Posts

Centralise the post anchor to the post and attach using 2 x No12 x 1 ¼" self drill screws

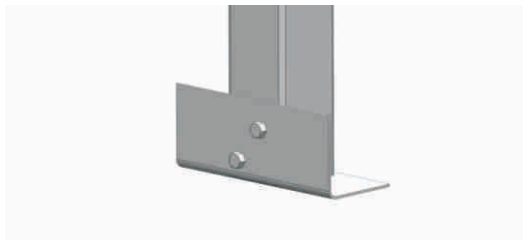

STEP 5

Cutting the Posts

Measure the height of the canopy/carport at the front and add to this dimension the depth of post that will be going into the ground. The total of this is the length at which your posts needs to be cut.

STEP 6

Fitting of Post to Gutter Section

Position the gutter section over the posts and ensure they are in the correct position and are spaced in accordance with the span chart. Ensure the post is square to the gutter section using a roofing square. Using 2 x No. 12 x 1 ¼" drill screws, secure through the front profile of the gutter into the post. Repeat on the inner side so that 4 screws in total are used to secure the post.

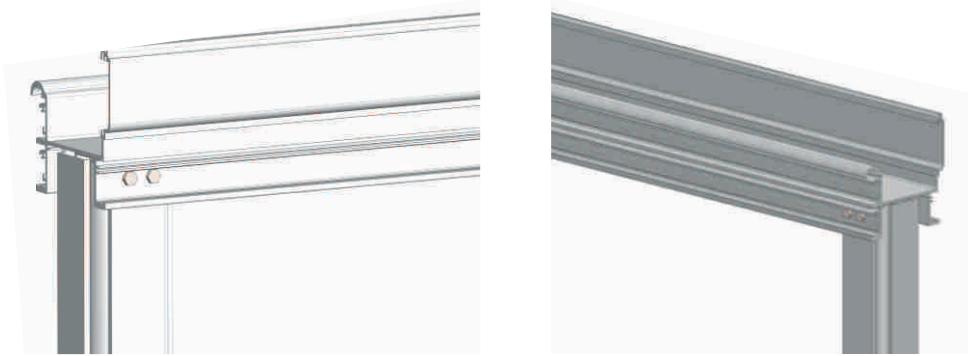

STEP 7

If your canopy or carport is longer than 6m, you may need to join the gutter sections as follows:

Joining Gutter Sections

You will need the following to join every gutter beam:

- 4No. flat aluminium joining plates: 2No. 18mm x 300mm x 2mm, 1No. 70mm x 300mm x 2mm, 1No. 61.5mm x 300mm x 2mm
- 1No tube of Sudaflex marine grade sealer
- 1No roll of masking tape
- 4No. M6 x 20mm hex headed bolts
- 4No. M6 self locking nuts
- 1No. 6.5mm drill bit
- 1No mastic gun
- 1No drill with 8mm self driller attachment
- Industrial wipes
- Roll of industrial tissue paper

1. Make sure you only use **Sudaflex**; normal silicon sealer will not do.
2. Now apply a liberal amount of Sudaflex to both sides of the eave beam on the internal vertical sections and the underside of the gutter where the plate fits into this will enable you to bond the four joining plates.

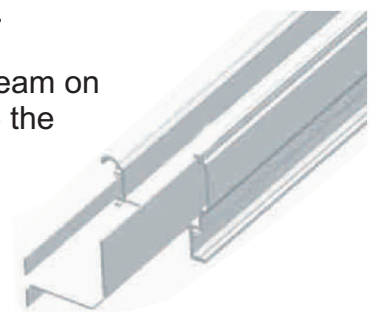

3. Flatten any excess Sudaflex with the spatula and apply a generous amount of sealer around every edge of both plates. Then insert all plates half way in to one half of the join.
4. Apply ample amounts of Sudaflex across all corresponding areas of the opposite gutter beam
5. You are now ready to marry the two gutter beams together but you must ensure they are flat and level to each other.

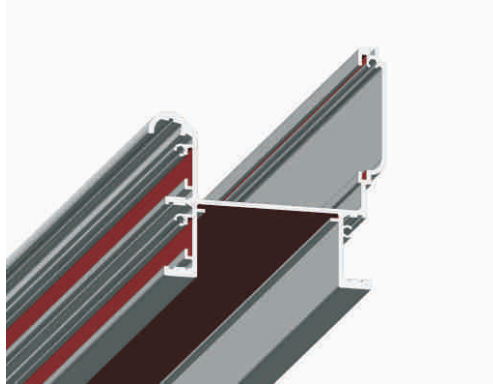

6. Once you have married the two beams together you must leave at least a **3mm gap between the two but no greater than 5mm**

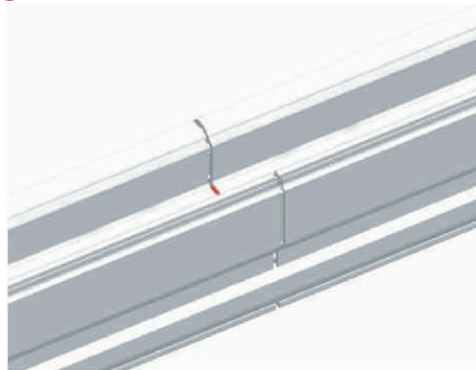

- 6a. Drill 2 No. x 6.5mm holes through the top 18mm joining plate and gutter channel and either side of the join line at the back of the Gutter Channel. Using the 6mm Hex Headed Bolts and Nuts supplied bolt through the gutter channel and joining plates and tighten up.
7. After around 15 to 20 minutes and once the sealer has had time to harden stand the gutter beam with legs attached up, and attach the bars as described in the above procedure.
8. Once your canopy is glazed, your legs are plumb and your gutter beam is level up and down, left and right, and front to back, ensure your gutter is dry and the surface temperature at least 4 degrees. If you are installing in the winter, you may need to use a heat gun.
9. Then you will need to apply the final amount of Sudaflex into the bottom of the gutter beam, please see diagrams below:
3mm gap between the two but no greater than 5mm

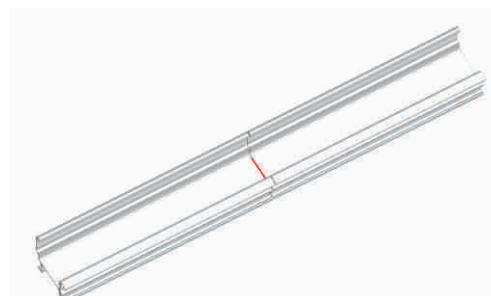
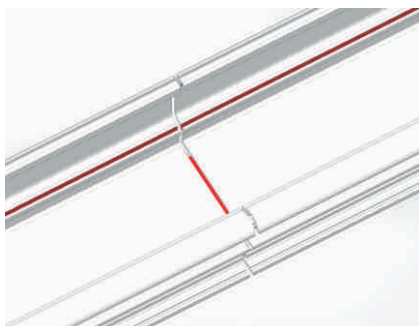

10. Apply a generous amount around the edges of the flat plates inside the gutter and ensure all gaps are filled with Sudaflex internally.



STEP 7a

Fitting the Gallows Support Bar

The gutter support bar is designed to span from post to post or from post to end cap underneath the gutter, fix the bar through the gutter channel using self drillers every 300mm both sides of the gutter as shown in the below diagram.

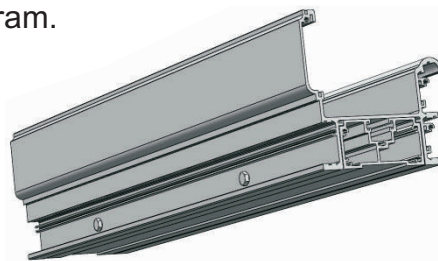

STEP 8

Stand Post & Gutter Beam Up

Using the excavated hole, position each of the posts into the centre of the hole and lean the whole frame forward so that the back of the posts leans against the front of the hole; please see diagram overleaf.

If the posts are to be surface mounted, please secure the posts ensuring they are plum and square.



STEP 9

Fitting of the Glazing Bars

Pre-drill the glazing bar that is going to fit into the gutter section. 15mm in from the edge and 30mm from the end of the bar drill your 6.5mm hole. Do this on both sides of the bar. This will allow the glazing bar to overhang the gutter section. Please see the images below.



Starting with the End Glazing Bar, push this bar into the wall plate so that it is pushed back as far as possible and ensure the outside profile lines up with the edge of the wall plate. Rest the other end of the glazing bar on the radius inner section of the gutter section.

Using a 6.5mm drill bit, drill 1 No. hole through the bottom radius profile of the wall plate ensuring this also goes through the flat section of the glazing bar. Locate a 6mm x 16mm pan pozi screw bolt through the hole and apply m6 nyloc nut. Using an 8mm ratchet and screw driver tighten up.

Repeat this process on the other side of the glazing bar. Please see the image below:

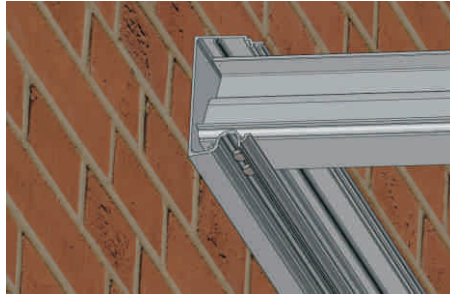

Make sure the glazing bar is in line with the gutter beam, then using the same fixing method as the wall plate secure the glazing bar to the gutter section. Your pre-drilled holes will determine where you drill through on the radius of the gutter section. Please see diagram below:



Repeat the above with the last glazing bar at the other end of the wall plate and gutter beam to stabilise the wall plate and gutter beam while you seal the wall plate in the following section.

DO NOT FIT ANY MORE GLAZING BARS AT THIS STAGE

STEP 10

Sealing Wall Plate Against the Wall

If flashing or silicone is required to seal the wall plate against the wall, it needs to be done prior to the glass sheets being fitted.

STEP 11

Glass Sheets

The glass sheet comes with a protective film fitted on the coated face. This needs to be removed prior to fitting. The side with the film needs to be fitted facing the sunlight.

PLEASE NOTE IF USING SELF CLEANING GLASS A MINIMUM PITCH OF 10° IS REQUIRED.

STEP 12

Glazing the Canopy

The glass will be supplied cut to the correct dimensions needed for the installation. The glass is 40mm wider than the inside to inside measurement of the roof bars as a rule.

Please refer to your CAD drawing at this stage as this will show you the inside to inside glazing bar dimension. Measure your glass to ensure it is 40mm wider than this dimension. The glass is therefore designed to locate 20mm inside each glazing bar. This allows for a 5mm gap between the centre of the bar and the glass, which is an allowance for any expansion.

When you push the glazing bar into the wall plate the gasket will have a tendency to fold back. You need to flick the rubber gasket out so it lips over the glazing bar and glass.

The glass into the glazing should be a nice, tight fit. You will need to apply a suitable lubricant to the top and bottom gasket prior to inserting the glass. (**Not supplied**) We suggest fairy liquid.

Always fit the glass into the next glazing bar at floor level before you lift and position into the fixed bar on the frame.

When you are fitting the glass sheet into the fixed glazing bar (with the next bar attached) it is recommended that you locate the top corner into position first with the other end about 200mm away from the finished position. When the glass is located in this position it is recommended that you use a Sach Cramp or ratchet straps to ensure the glass stays within the glazing bar and does not spring out while you are pushing the glass into the bar. Then working from that top corner you steadily work along pushing the glass into the glazing bar which reduces the gap until the full length of glass is located into the glazing bar. See *illustration below*

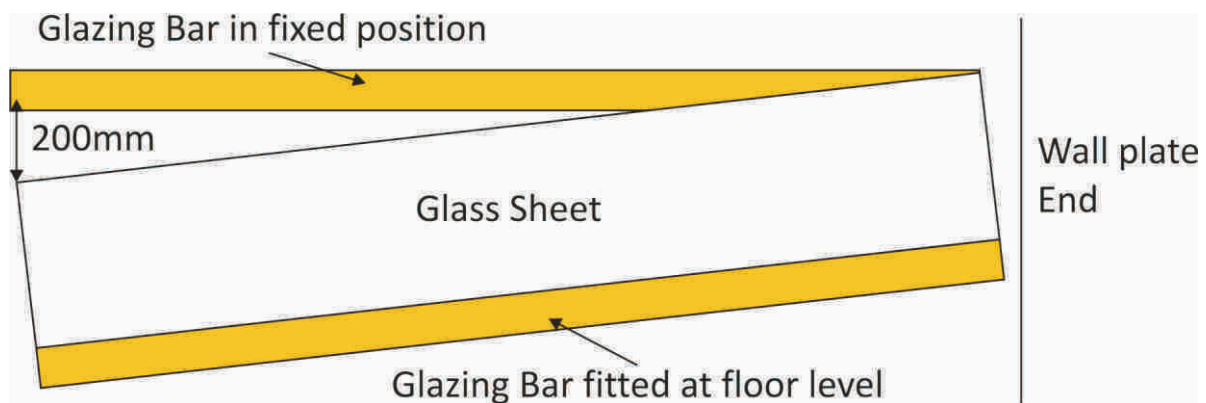

Secure the glazing bar in place as shown in STEP 9

STEP 13

Fitting of the 'F'-Section

Secure the glazing bar to the gutter section using M6 X 16MM Pan Pozi Bolts and M6 Nuts.

Ensure the end of the glass is fitting flush with the edge of the glazing bars as shown overleaf.

The F section is supplied pre cut to the correct width of the inside to inside glazing bar dimension. Please measure this width and check against your CAD drawing.

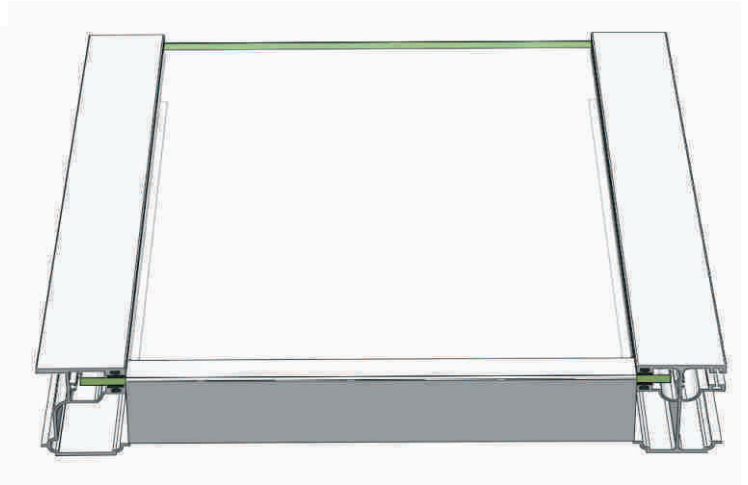
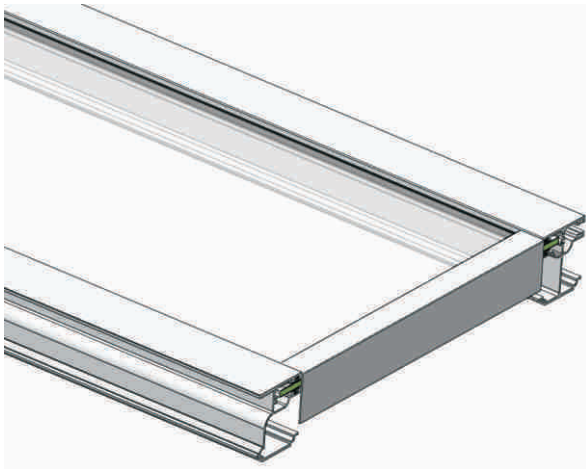

STEP 13a

Fitting of Bar End Plates

Secure the bar end plate into the end of the glazing bar using a No. 10 x 25 hexagon headed screw (supplied). Please see the image below.

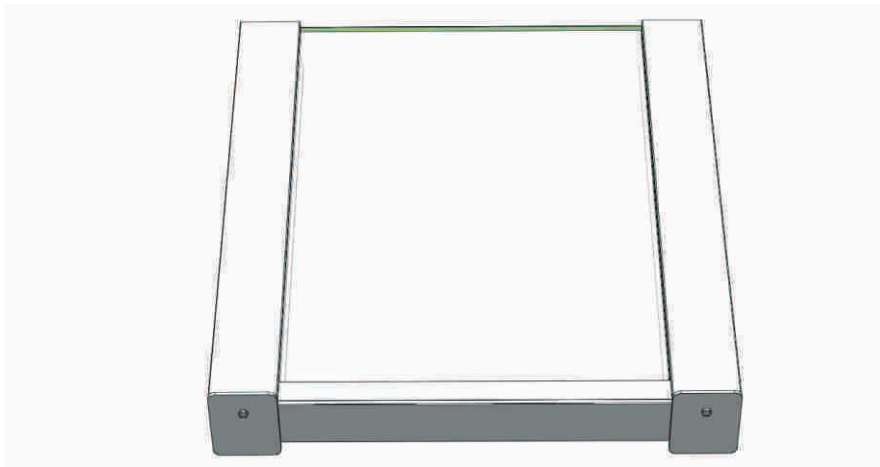

STEP 13b

Fixing the Gutter Trim

There are 3 trims the same length as the gutter, if the gutter is over 6m and has a join then stagger the trim so that the join is in a different place. The trim fits into the channel on the front and the back of the gutter, 1 trim on the front and 2 trims on the back (inside of the gutter). Simply hold the trim close to the channel and using a rubber or fibre mallet tap the trim into place ensuring the bottom 2 trims have the flat section facing down. The top trim on the inside is fitted with the flat section of the trim facing upwards.

STEP 14

Fitting of Gutter End Caps

Ensure the gutter is completely dry, then apply a continuous bead of Sudaflex around the end of the gutter extrusion, then line up the 4 holes on the gutter end plate with the port holes on the end of the gutter section and using 4 No. x 5/8" self tapping screws secure in place. Finally using a dobbing stick or finger with disposable gloves apply a bead around the internal gutter section at the end. Repeat at the other end. Please see diagrams below:



STEP 15

Fitting of Wall Plate End Caps

Line up the 2 No. holes on the wall plate end plate with the port holes on the end of the wall plate section and using 2 No. x 5/8" self-tapping screws secure in place. Repeat at the other end. Please see diagram below:



STEP 16

Make Sure Your Canopy/Carport is Square

To ensure the carport is square, using the roofing square, attach one edge of the square to the wall plate and the other edge will need to continuously touch the other edge of the square. This will ensure the gutter beam is perpendicular to the wall plate.

STEP 16a

Ensuring your Canopy/Carport is Level

Using a spirit level ensure the front beam is completely level and your posts are plumb.

STEP 17

Concrete around the Posts

Using the correct aggregate apply to the excavated holes and make good.

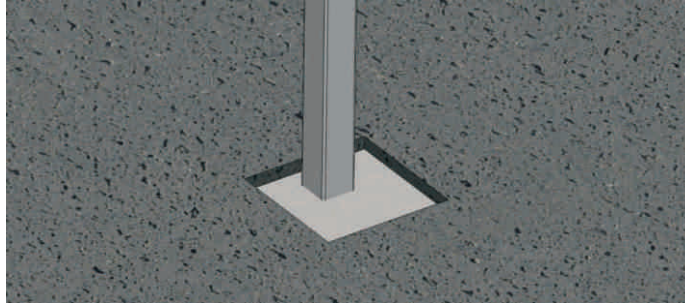

STEP 18

Victorian Upgrade Drainage System

If you are not installing the Victorian Upgrade, please skip this step and move onto step 18a.

Drill a hole no more than 45mm diameter in the gutter section where your post is to be located. Push the post in to the gutter section below the hole. Please see diagram below

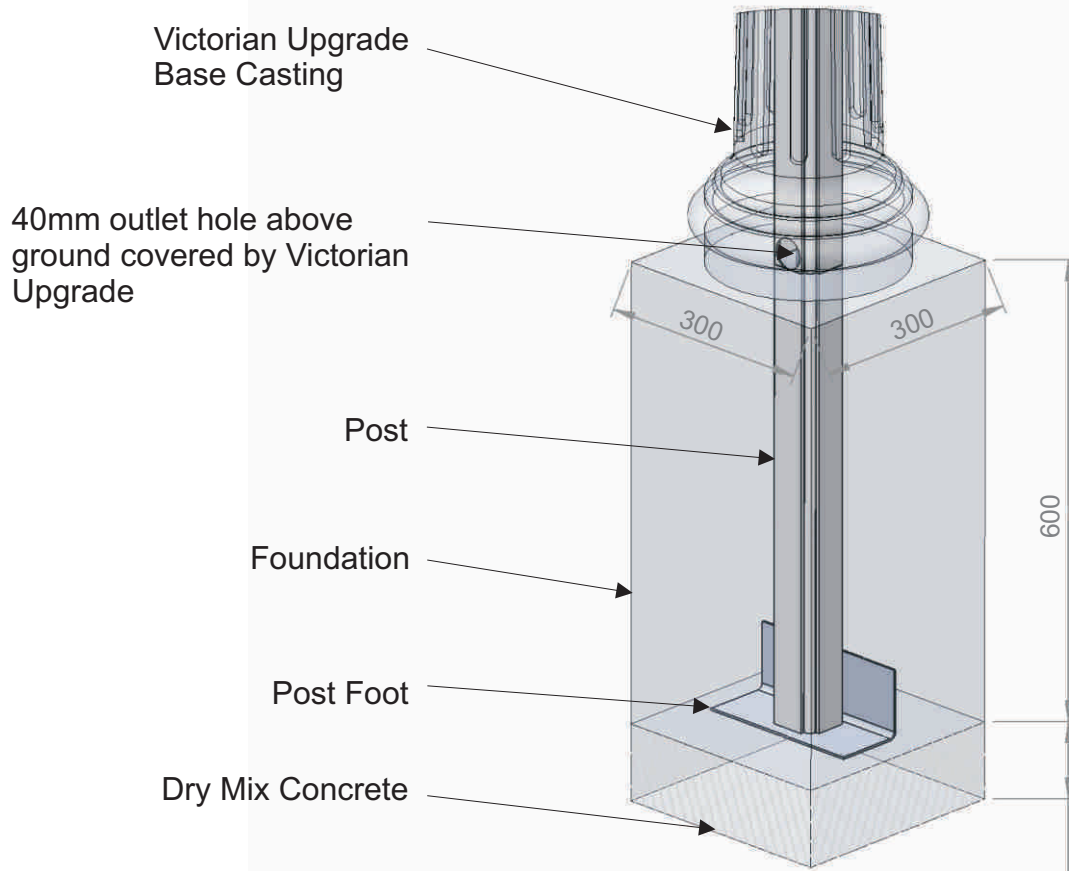

Note:

1. You must ensure the bottom of the hole has at least 100mm of dry mix concrete under the post to prevent subsidence of the post, and that is compacted hard.
2. Ensure as you fill the 300 x 300 x 600 foundation, that you fill the centre of the post level to the bottom of the 40mm hole to prevent rainwater going into the bottom of the post.
3. We recommend that when installing above ground outlets, you perform this procedure on every post to minimise puddles.

Disclaimer: We cannot be held liable for puddles of excess rainwater around the column base.

STEP 19a

Standard Drainage System

Drill a hole 45mm diameter using a hole saw in the gutter section where your downpipe is to be located, Insert the outlet into the hole and tighten. Push the downpipe in to the gutter section below the hole over the outlet. Using the downpipe clips provided secure to one of the posts or the wall depending on the position of your outlet.

STEP 19b

Capping off the Fixings

Using the supplied caps, ensure the fixings have been capped off and the structure has been cleaned.

STEP 20

Applying the Stickers

When applying the logo ensure to fix one at each end.

STEP 21

Fitting the Gutter Support Channel

If supplied, then the Gutter Support channel (see profile image) fits directly underneath the Gutter Channel. It is held in place by using No12 x 1 ¼ drill screws every 300mm directly through the flange on both the outside and inner face.

STEP 21a

Fitting the Gallows Brackets

Once the Gutter Support Channel is fitted you can now fit the Gallows Brackets. Using 2 x No12 x 1 ¼ drill screws fix the Gallows brackets directly into the post and then into the support channel you have previously fitted. See photo below. Using caps provided cap off all screw heads. Please see images overleaf.

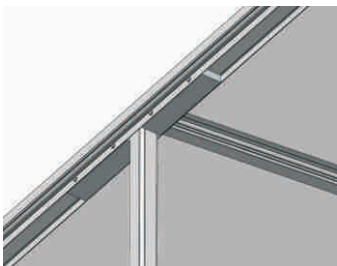

Image shows gutter channel fitted.

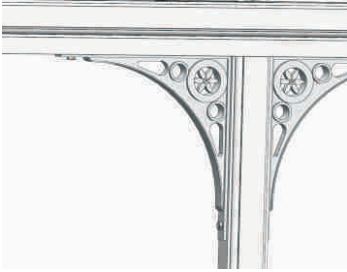
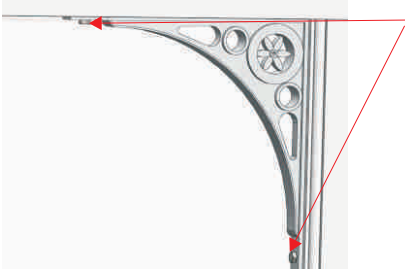

Image shows gallow brackets fitted to gutter channel and post.



Please see the position of the fixings.

STEP 22

Lighting installation (if required)

Inside of the light channel you will find a 12 Volt LED self-adhesive strip light, to access this just unscrew the aluminium end cap and slide out the polycarbonate lenses. You will need to connect the black and red cables to some compatible flex cable that is small enough to run through the trims on the alfresco, or through the wall plate and the main bars.

Attaching the light channel to the Simplicity 6 gutter beam:

Before you attached the light channel please consider the cable route and ensure you have enough cable to run it through the main bar and out of the wall plate to the capacitor. Then you need to drill up through the trim channel above the light channel into the main bar next to the main bar fixing bolt, then crimp the cables that exit the light channel with the additional cable required for the run, if the hole in the light channel is not already drilled, slide the lens out of the light channel by unscrewing the aluminium end cap and drill the hole using a 6mm drill bit ensuring it is aligned to the main bar hole you have just drilled. Once you have passed the cables through the hole simply snap the light into place or using a rubber mallet tap it into the light channel as below image. Then run the cables up the main bar and out of the wall plate at the desired location.



Attaching the lighting to the Simplicity 6 wall plate:

To do this drill a hole through the back of the light channel (facing the wall) in the desired location for cable exit using a 6mm drill bit, crimp the cables to the red and black LED cables exiting the light channel and feed the extended cables through the hole and run them into the building or the plastic external box supplied and connect them to the capacitor. Then slide the polycarbonate lens back into the light and screw the end cap back on to the light channel. The capacitor will then need to be powered to the mains either via a fused spur or a plug socket as per the specification detailed on the lighting capacitor.

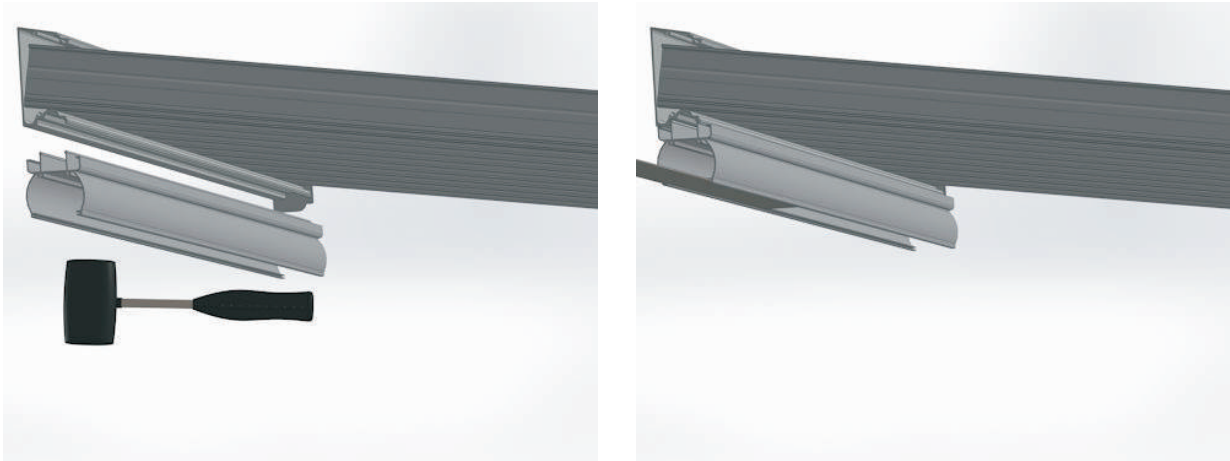

End.

