



Installation Guide

Contemporary Alfresco

Tools Required

Below is a list of tools that you will require to install you're the Contemporary Alfresco System.



*Please refer to your CAD drawing for each individual order as this will show the roof bar spacing as per your order. This installation guide is generic and the centre's spacing is given as a guide example only.

Parts Supplied

Below is a list of the parts supplied with your new Simplicity Canopy. Please check that all parts are present before starting installation.

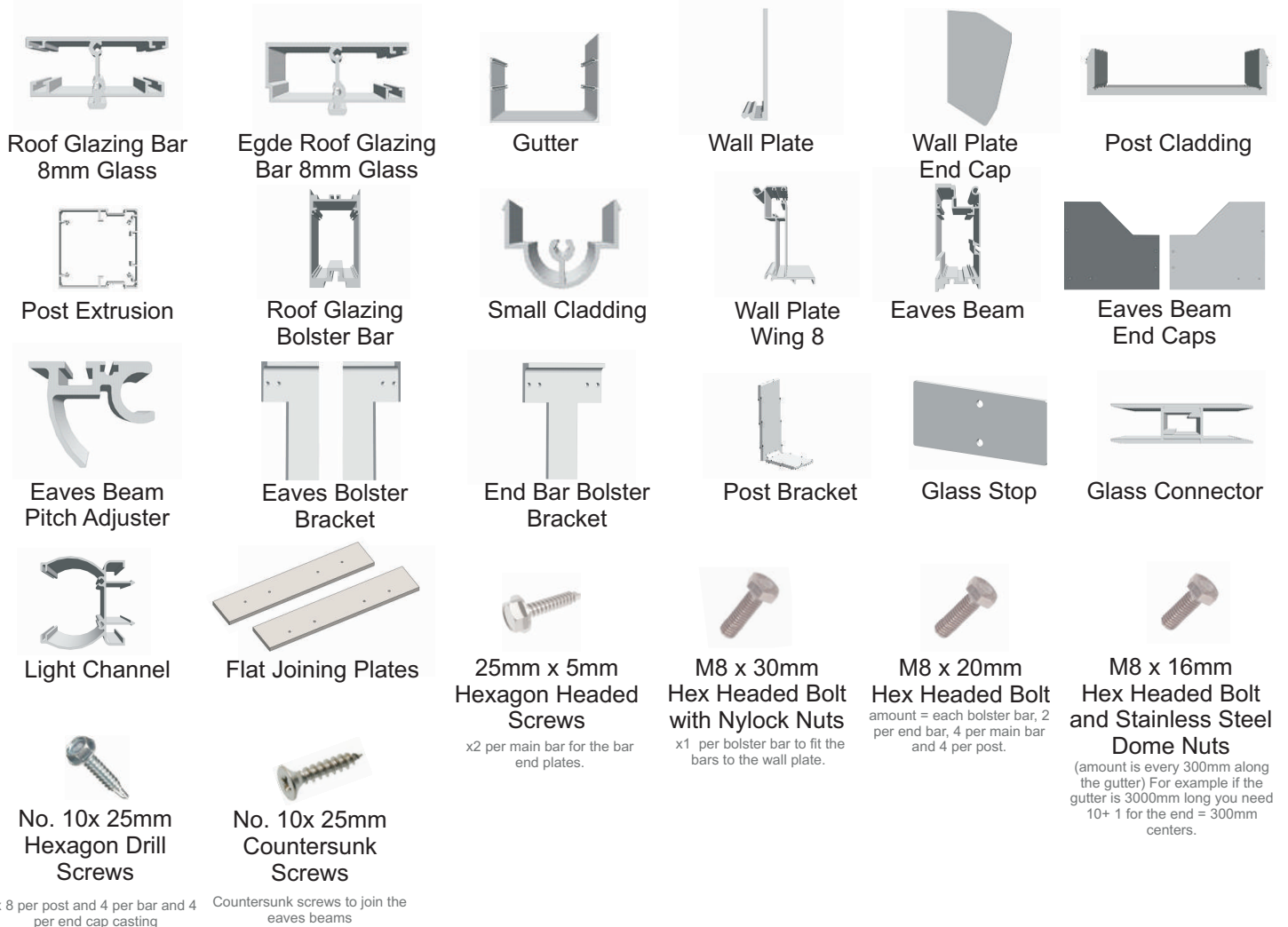

Please reference the CAD during installation as this is just a general guide, your CAD will provide you with more specific details for your install.

Cross Section CAD Drawing

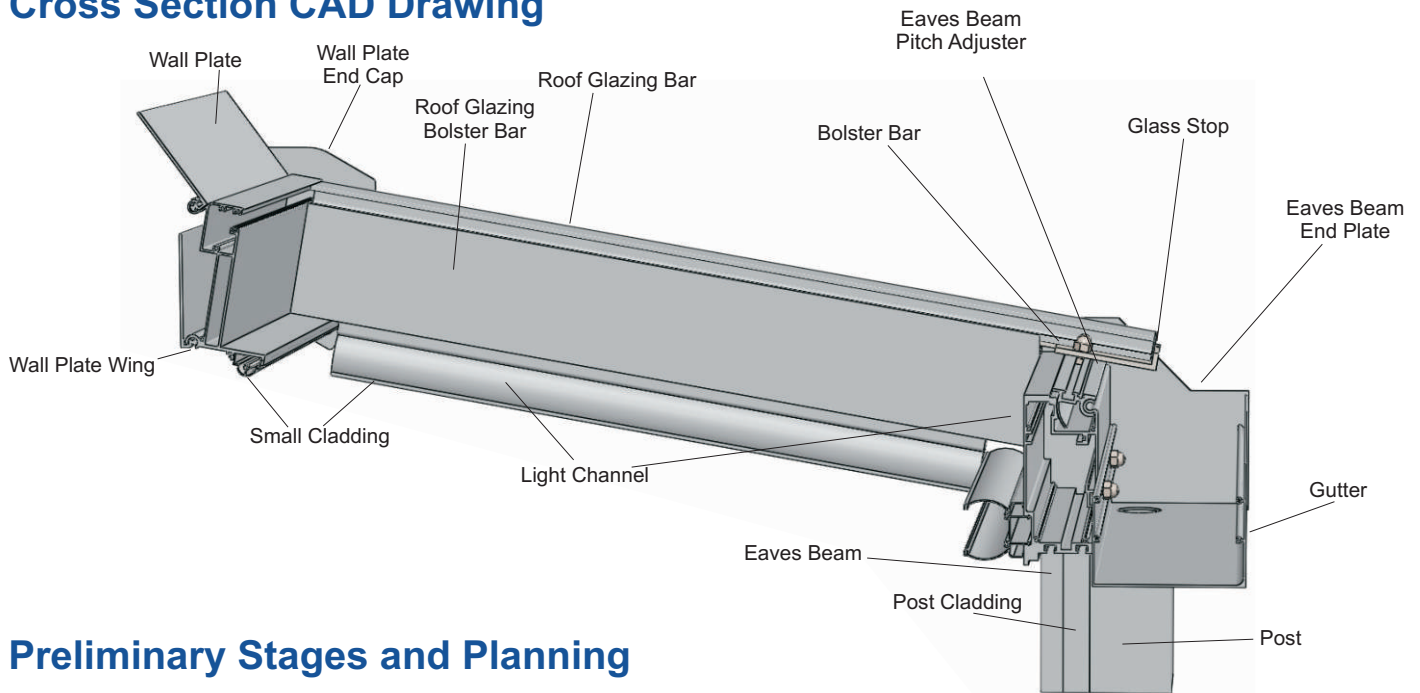

Preliminary Stages and Planning

Before starting your install please check all components for quantity and damage.

Below is a Roof Span chart which you MUST refer to in order to establish the maximum centre to centre dimensions of your roof bars and posts.

SPAN CHART	Up to 6m Projection	POST SPACINGS	Up to & Including 6m Projection
Simplicity Alfresco	800mm Roof Spacing's	Simplicity Alfresco	6m Post Spacing's

PLEASE NOTE – A MAXIMUM OF 500MM OVERHANG ON THE GUTTER IS ALLOWED



You have two options for fixing the posts to the ground, **Option 1** is to bolt down to a pad foundation. **Option 2** is to cast the posts into the ground, see illustrations. With both options you need to be mindful of the drainage connection, if you are connecting underground you need to allow for the rainwater fall. Both options need the cleat installing into the bottom of the post to enable the bolt down or to help with wind uplift.

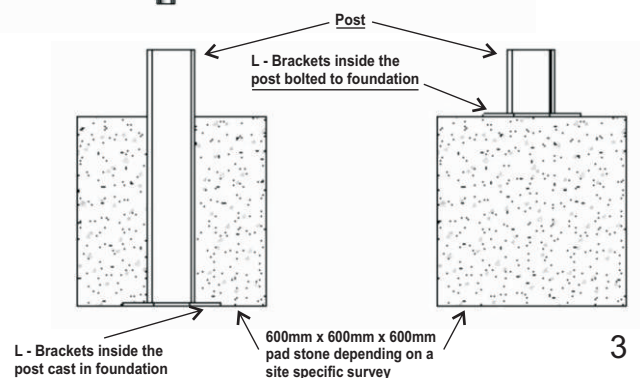

You are now ready to start installing the structure, following all steps within this guide.

Ensure you work to the cad drawing supplied with the job

Lighting (if required)

The lighting consists of an aluminium extrusion that can fit to either the bottom of the wall plate, or the back of the eaves beam. When installing lighting please consider cable exist and cable entry to the light channel. The lighting also comes with an electrical capacitor for each 6m of light and an optional external grade plastic box to house the capacitors if the installation requires that they be mounted outside.

STEP 1

Foundation Hole Positions for Posts

When the simplicity Alfresco was ordered a size was confirmed for the height at the front and the back, please reference these measurements because the canopy has been cut to the correct angle. Then establish the height of the structure at the back (wall edge) and the height at the front. The height at the front must be above 2.1m to underside the gutter to meet the minimum legal head height requirement.

Once you have established your height at the front and back, deduct the height at the front from the height at the back to give you "The Fall" (x). Measure distance 'x' up the wall and position your roof glazing bar at this height on the wall. Let the other end touch the ground and where that touches will be the centre of your hole for the foundation.

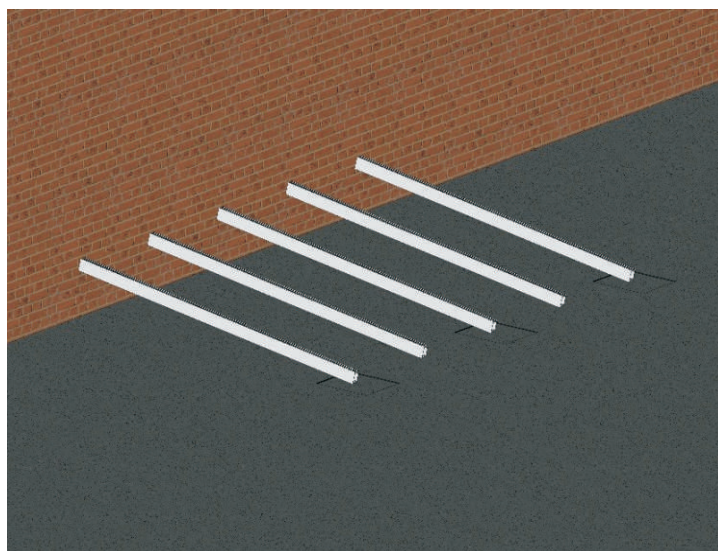

IMPORTANT: Use Roofing Square to ensure the bar used is held square to the wall.

STEP 2

Digging of Holes for foundations

Please refer to the chart below to determine the size of the holes that need to be dug. We recommend a minimum of 600mm x 600mm x 600mm of concrete.

Please note the following are for guidance only and will need to be verified by a structural engineer.

All Canopies are recommended to have a minimum size of following:	600mm x 600mm x 600mm deep
---	----------------------------

Ensure that when the excavations are complete that the base of the holes is level with each other.

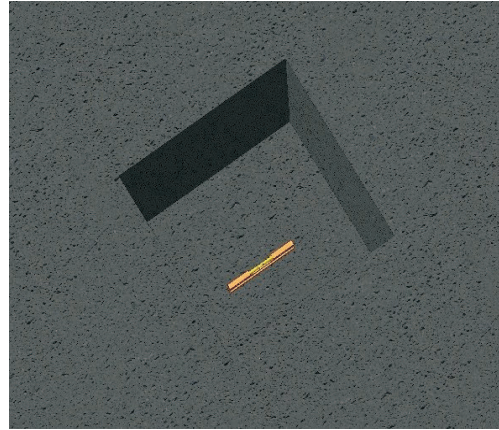
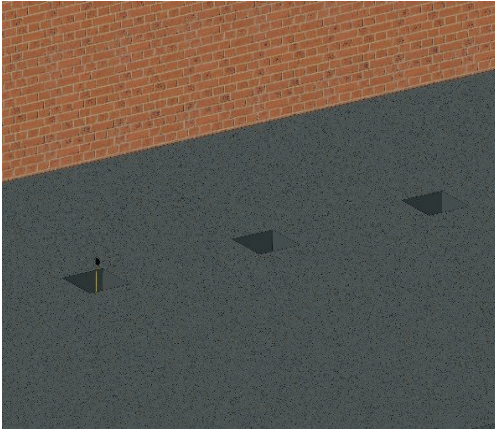

STEP 3

Fitting of wallplate to the Wall

Attach the wall plate strip to the wall using suitable fixings (not supplied). Recommended spacing for these fixings is 200mm.

YOU MUST ENSURE THE WALL PLATE IS NOT TWISTED OR BOWED AS THIS WILL PREVENT THE WALL PLATE WING FROM BEING FITTED. USE A SPIRIT LEVEL TO MAKE SURE THE WALL PLATE IS FITTED LEVEL.

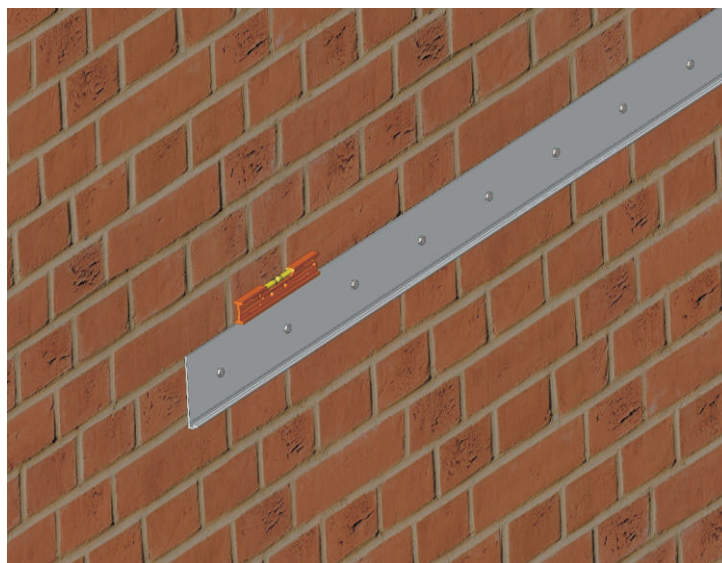

STEP 4

Preparation of the Wall Plate Wing

Refer to CAD drawings for centre to centre bar dimensions

Measure 35mm in from one end of the Wall plate and mark before you drill. Ensure the 8.5mm hole is in the centre of the bolt channel on the wall plate wing. Once this is done drill an 8.5mm hole.

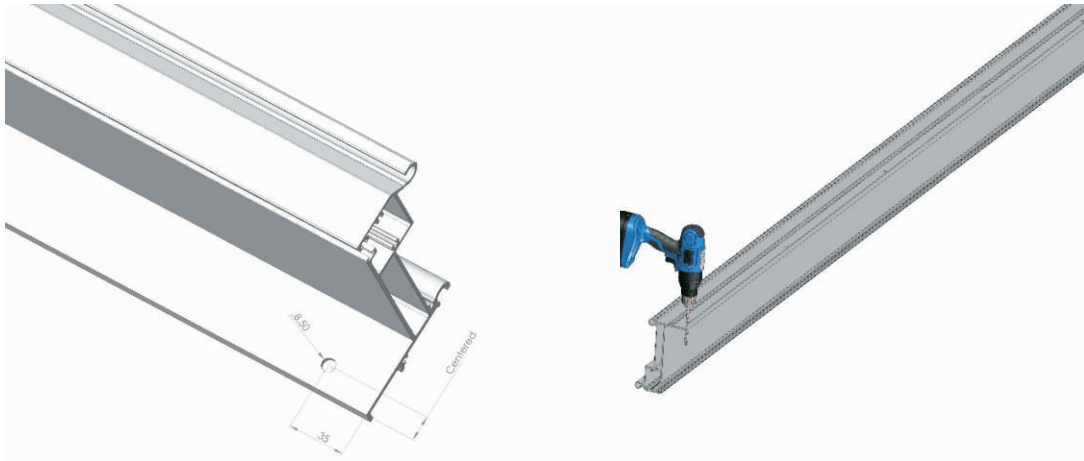

REPEAT THIS PROCESS AT THE OTHER END OF THE WALL PLATE WING

You now need to reference your glass WIDTH before you drill any more holes. Your hole centres now need to be spaced 20mm wider than your glass width.

Example: If your glass width is 750mm your hole spacing's need to be 770mm.

Once you have calculated this measurement MARK you wall plate and ensure they are spaced equally BEFORE drilling.

Once you are happy that the spacing's are equal and matching the cad drawings, proceed to drilling using an 8.5mm drill bit.

STEP 5

Install the wallplate wing onto the wall plate.

Once you have set up your access equipment, drill 2 holes through the glass channel to help retain the wall plate wing on the wall as a suitable position to obtain a fixing, then hook the wall plate wing onto the wall plate and fix into position to prevent it falling while you carry on with the rest of the installation.

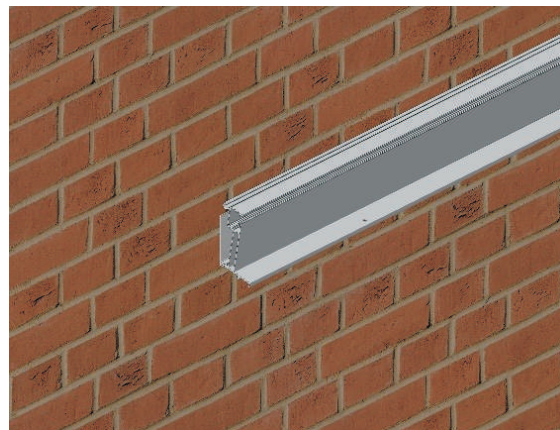
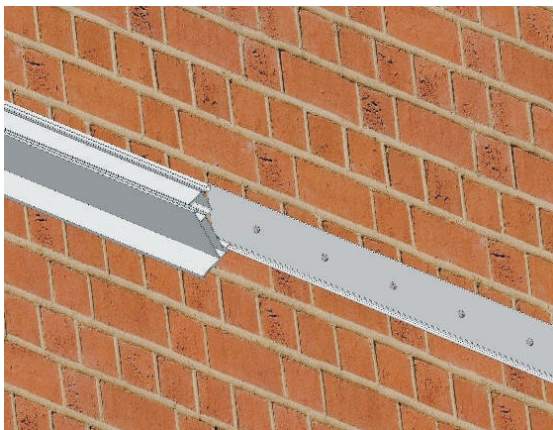

STEP 6

Attach the Gutter Section to the eaves beam.

Attention only attach the gutter now if you are installing a structure at 15 degrees or lower (please refer to your CAD drawing for confirmation) to avoid a clash with the gutter when glazing. If your structure is over 15 degrees please attach gutter after glazing the roof.

Drill the gutter in the centre of the two lines as the below image (fig 3) 50mm from the edge and at around 300mm centres along the whole gutter, slide the relevant amount of m8 x 16mm bolts into the eaves beam with the thread sticking out.

Before you connect the two parts make sure you apply a thick bead of sudaflex along the inside of two extrusions just above the bolts to prevent the rainwater running between the two sections.

Then marry the two parts together and align the two ends, then tighten as below.

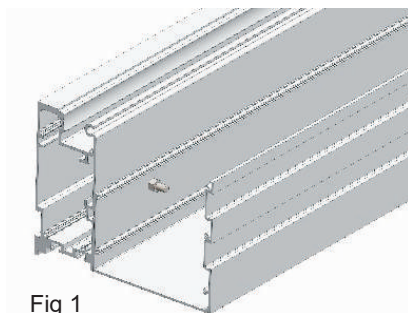

Fig 1

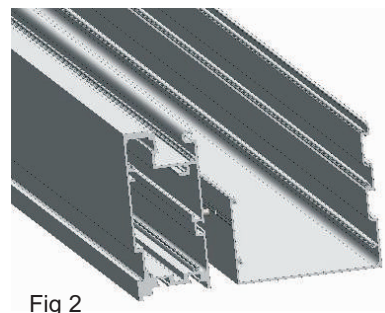

Fig 2

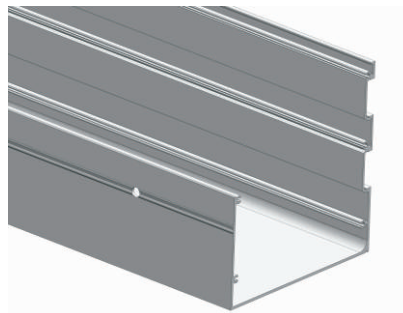

Fig 3

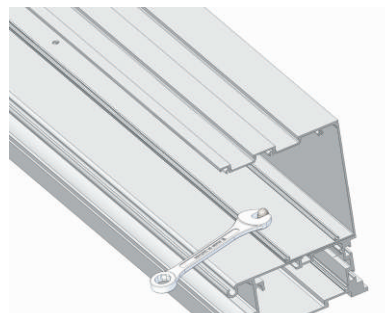

Fig 4

If the gutter is longer than 6m, please include step 6a.

STEP 6a

Ensure all gutter joints are joined over a post position to maximize the wind and snow loadings on the structure

Using the two 300mm long x 59mm x 8mm thick joining plates supplied place the plates into the channels as shown in the below pic to 150mm deep and drill using the countersink drill bit, then screw together using the No 15 x 25mm screws, repeat the process on both sides of the join and make sure you stagger the gutter joints and the front gutter cover to improve the strength.

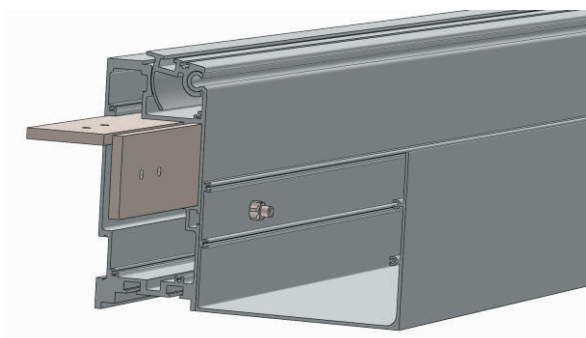

STEP 7

Install the gutter plate at both ends of the gutter / eaves beam.

To do this simply screw the gutter end plate to the outside of the gutter using the small stainless steel domed headed screws supplied see images below.

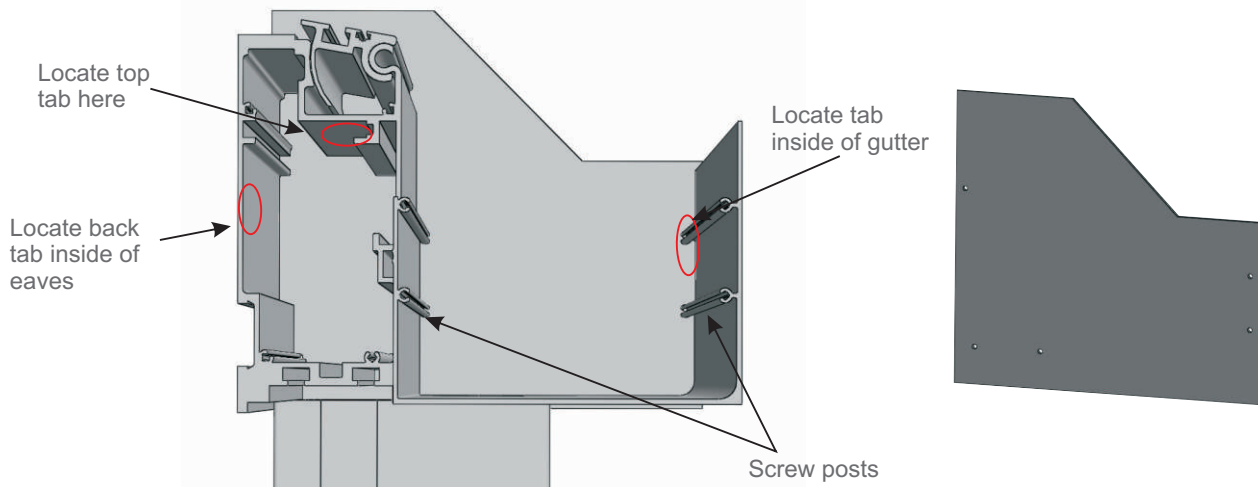

To seal these, you will need the tube of sudaflex (both supplied). Apply another continuous bead of Soudaflex around the entire inside profile and ensure the 2 screw ports are filled with Soudaflex.

Repeat this process at the other end

STEP 8

Now install the eaves beam pitch adjuster and ensure you slide the correct amount of m8 x 20mm bolts into the eave beams pitch adjuster before you fix the side caps onto the eaves beam.

STEP 9

Each Leg has 1 cleat at the top. The cleat has 4 pre drilled holes, if the posts are at the end of the eaves beam measure 32mm from the end of the eaves beam to the start of the cleat as below, this will ensure the clip on cladding does not project out past the end of the casting.

Then attach the cleat as shown, ensure they are secured tight using all 4 m 8 bolts.

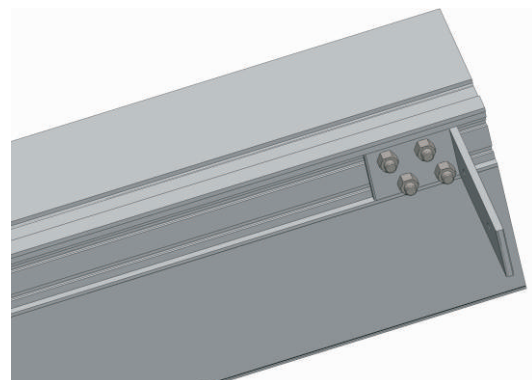
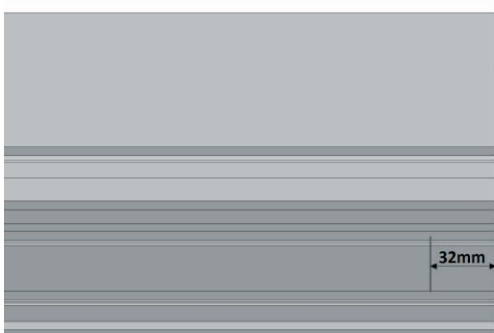

Then attach all other cleats in the positions you want the posts to be. If the structure is longer than 6m and the gutter needs to be joined, ensure the join is over the post and follow the joining procedure

STEP 10

Fitting of Post Feet to Post

Slide the two post feet into the bottom of the post and attached using 2 No 5.5mm x 25mm self drilling screws as below image

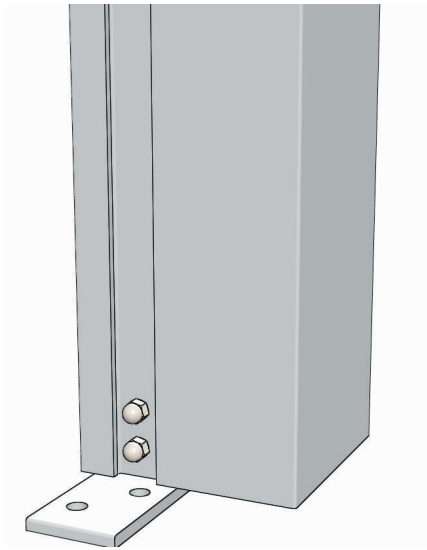

STEP 11

Cutting the Posts

Measure the height of the structure at the front and add to this dimension the depth of post that will be going into the ground. The total of this is the length at which your posts need to be cut to size.

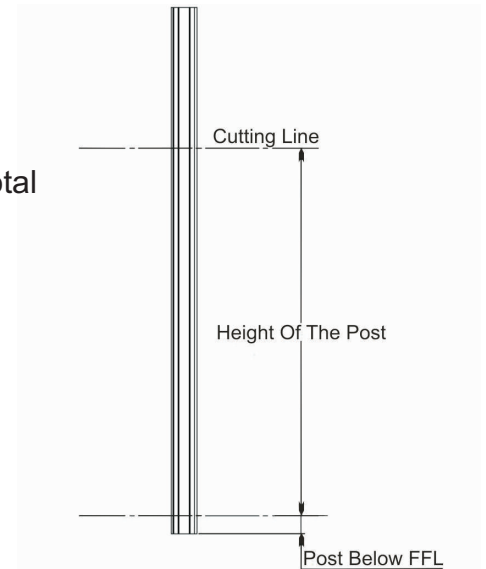

STEP 12

Drill the Posts

Drill each post using a 4mm pilot drill bit at the position to correspond to the cleat (40mm down and 40mm in from the inside edge of the post), ensure you do not clash the fixing with the cladding that will be fitted at a later stage. Repeat on the opposite side, ensure that the post foot is facing the desired orientation to suit your hole and does not clash with the sides of your foundation.

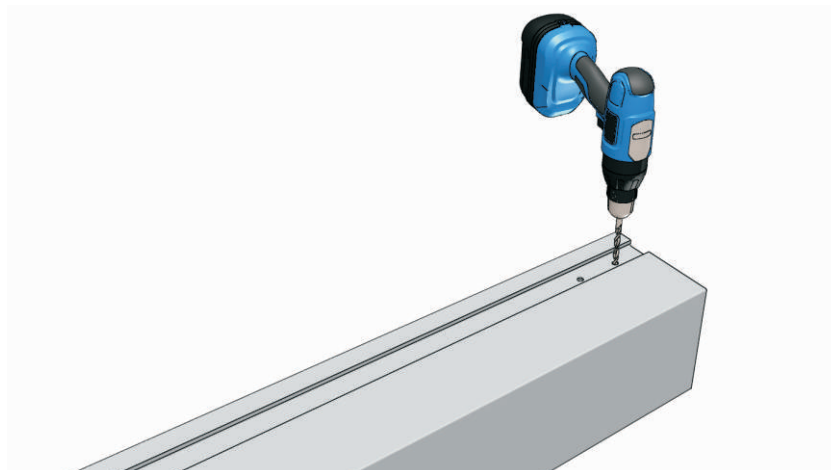

STEP 13

Fitting of Post and downpipe to eaves beam

Slide the post over the fixed cleat on the gutter section and ensure the post is touching the underside of the gutter beam i.e. no gap. Then drill the downpipe spigot hole and insert the spigot and attach the plastic downpipe and fix the downpipe to the spigot using a screw then align the post over the post bracket and fix the post into place using the 4 no 5.5mm x 25mm self drilling screws. Ensure the downpipe outlet is in the desired position and drill the post to suit the outlet.

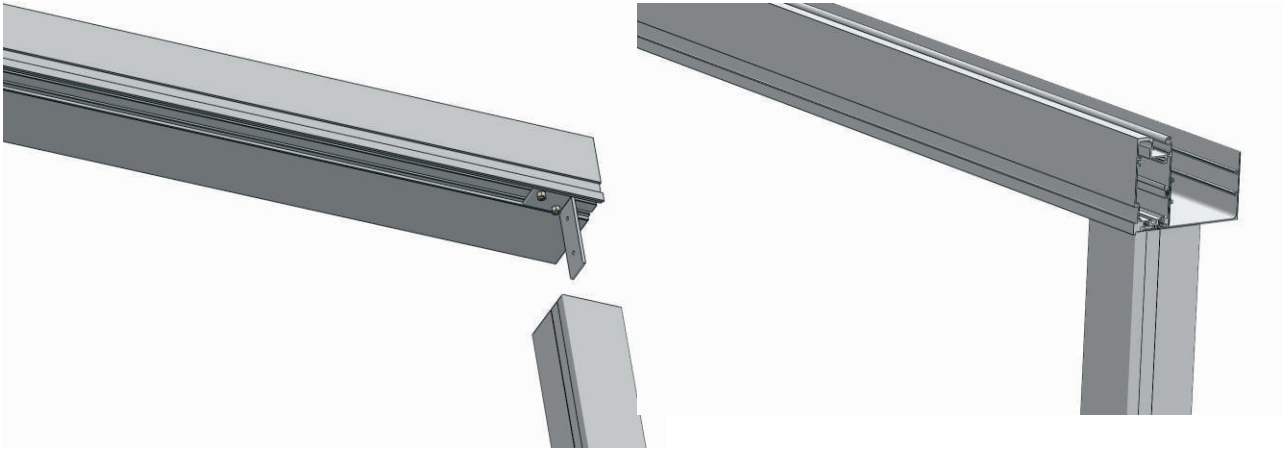

STEP 14

Preparing Glazing Bars for Glazing

Slide the edge roof glazing bar into the bolster bar first and then do the same to the other edge bar, then repeat for all bars.

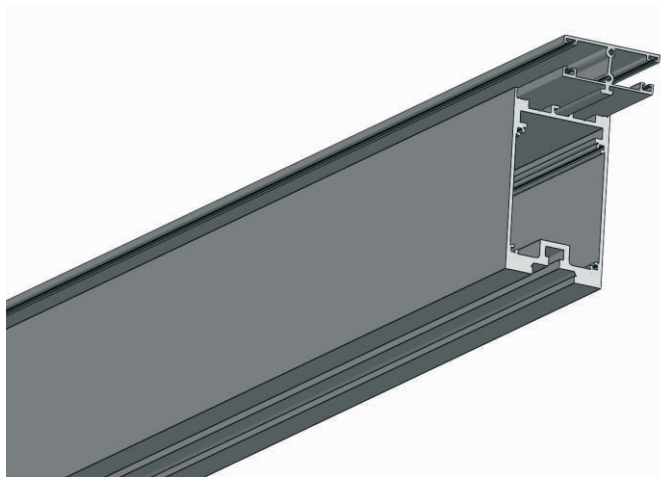

Do not fit the glass stops yet.

STEP 15

Stand Post & Gutter Beam Up

Before you stand the front of the structure up ensure you add the relevant amount of m8 x 20mm bolts into the channel of the eaves beam pitch adjuster so that you can bolt the main bars down. There are 2 bolts per end bar and 4 bolts per main bar - refer to CAD drawing.

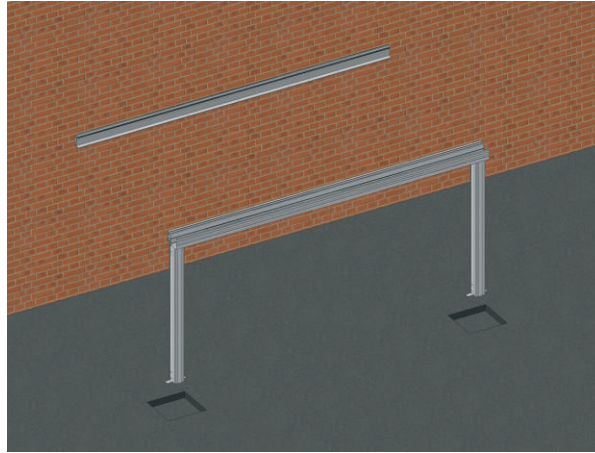

Using the excavated holes position each of the post into the centre of the hole and stand the whole frame including eave beam and gutter upright then brace as necessary to hold it upright.

Depending on the size you may need to brace this with timber or something similar to prevent it falling.

STEP 16

Before fixing the first glazing bar please cut the first 110mm of the upstanding flipper gasket from the eaves beam pitch adjuster, now fix the first glazing bar (complete with bolster bar) to the gutter and eaves beam and to the wall plate wing using the m8 x 20mm bolts supplied and nylock nuts.

Important! DO NOT OVER TIGHTEN THE BOLTS AT THE WALL PLATE WING END AS THIS WILL DISTORT THE WALL PLATE WING.

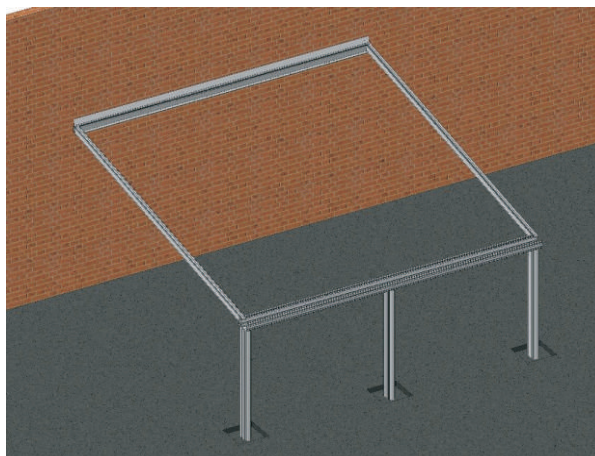

STEP 17

Repeat step 16 at the other end of the structure so that the frame is solid.

STEP 18

Using a square against the wall plate wing and the bolster bar, move the front legs either left or right to make sure the structure is square.

STEP 19

Fitting of The Remaining Glazing Bars

Follow step 18 until all bars are installed. Cut 160mm of upstanding flipper gasket before you place each glazing bar, this is the amount of material required to enable the front bolster bar bracket to sit flat on the eaves beam pitch adjuster.



STEP 20

Sealing Wall Plate wing against the Wall

If flashing is required or silicone to seal the wall plate against the wall it needs to be done prior to the glazing panels being fitted.

STEP 21

Glass sheets

The glass sheets come with a protective film fitted to one side. This needs to be removed prior to fitting. The side with the film is the TOP face, make sure this is the right way up.

STEP 22

If your structure is over 3m you will have glass connectors and you will need to join the glass using the connectors supplied as follows:

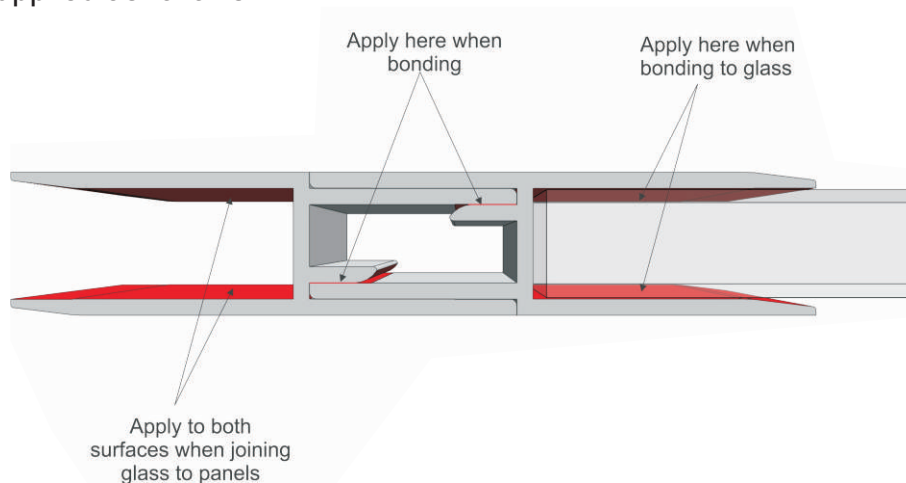

Bond one half of the glass connector to the glass (see illustration below for application of sudall crystal clear silicon, supplied). Use a liberal amount, approximately an 8mm bead on both sides (**do not use a cheap version**) of the connector as above in both the underside and bottom, make sure it's the right way around to allow the water to run over the top of the connector (the tapered edge facing the highest end of the canopy)

Repeat for all of the glass panels.

One half of the glass connector is also used at the gutter end on the lowest section of glass to allow for drips to ride into the gutter, bond them in the same way.

STEP 23

Glazing the Structure with Glass

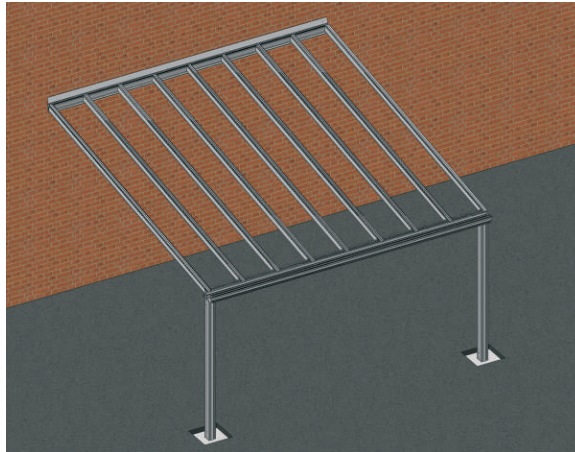

We recommend the use of a co2 geni hoist for the glazing process as it can sit directly under the sheets of glass

Depending on the pitch you can glaze the structure with the front gutter cladding already installed, however we recommend fitting this after the roof panels have been installed.

Using a soap solution and a 25mm paint brush (not supplied) lubricate the edges of the glass panels

Then slide the glass complete with connector into the two bars all the way in to the wall plate wing.

Then repeat above process to lubricate the panel and Insert the next section of glass complete with the glass connector installed.

Ensure you seal the glass connector before two connectors meet together .

One half of the glass connector is also used at the gutter end on the lowest section of glass to allow for drips to ride into the gutter, bond them in the same way. Now fit the front glass stop using x2 M6 x 30mm self tapping screws and install the glass plates as you go.

Clean the tops of the each glass panel as you go!

Continue this process until your structure is fully glazed.

STEP 23a

Glazing the Structure with Polycarbonate

First you will need to notch the ends of the poly sheet capping to allow for the capping to go into each bar, the poly sheet capping fits into the bar from the front and requires a notch to miss the eaves bolster bar, trim this with a thin grinder disk or suitable aluminium saw.

Depending on the pitch you can glaze the structure with the front gutter cladding already installed, however we recommend fitting this after the roof panels have been installed.

Using a soap solution and a 25mm paint brush (not supplied) lubricate the edges of the poly panels.

Then slide the poly complete with f section into the two bars all the way in to the wall plate wing.

Then repeat above process to lubricate the panel and Insert the next section of polycarbonate complete with the F section / poly sheet capping already installed.

Ensure you seal the poly sheet capping around the edges and the top of the sheet before installation.

Now fit the front glass stop/front bar caps using x2 M6 x 30mm self-tapping screws and install the glass plates as you go.

Clean the tops of the each poly panel as you go!

Continue this process until your structure is fully glazed.

STEP 24

Make Sure your structure is Square

To ensure the structure is square, using the roofing square, attach one edge of the square to the wall plate wing and the other edge will need to continuously touch the other edge of the square, this will ensure the gutter beam is perpendicular to the wall plate.

STEP 25

Ensuring the structure is level

Using a spirit level ensure the front beam is completely level and your posts are plumb.



STEP 26

Concrete the post in or bolt down

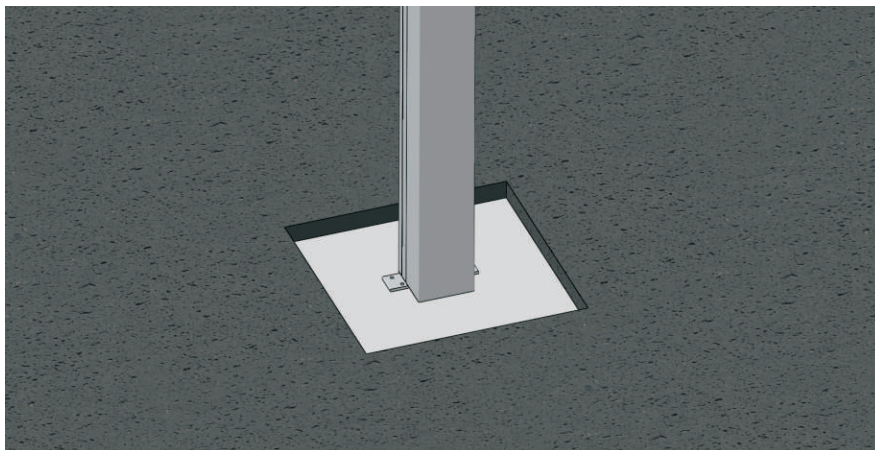

STEP 27

Clip on the two side claddings for the posts and the rear cladding, leaving the front post downpipe cladding for now.

STEP 28

Make good around the posts

STEP 29

Install the trims for the underside of the wall plate

If you are not installing lighting, now install the small cladding on the underside of the wall plate to hide all bolt heads.

STEP 30

Lighting installation (if required)

Inside of the light channel you will find a 12 Volt LED self-adhesive strip light, to access this just unscrew the aluminium end cap and slide out the polycarbonate lenses. You will need to connect the black and red cables to some compatible flex cable that is small enough to run through the trims on the alfresco, or through the wall plate and the main bars.

Attaching the lighting to the Alfresco eaves beam:

Before you attached the light channel please consider the cable route and ensure you have enough cable to run under the main bar and out of the wall plate to the capacitor. If the hole in the light channel is not already drilled, then you need to drill up through the top of the light channel close to the back so that the cable cannot be seen from the ground using a 6mm drill bit, ensuring the hole is aligned with a main bar so it can be covered with the aluminium trim, then crimp the cables that exit the light channel with the additional cable required for the cable run. Once you have passed the cables through the hole simply snap the light into the channels along the back of the eaves beam or using a rubber mallet tap it into the light channel as below image. If you struggle consider using a large "G" clamp to help it to snap into place. Then run the cables up the main bar and out of the wall plate at the desired location. Then cover the cables using the aluminium trims supplied.

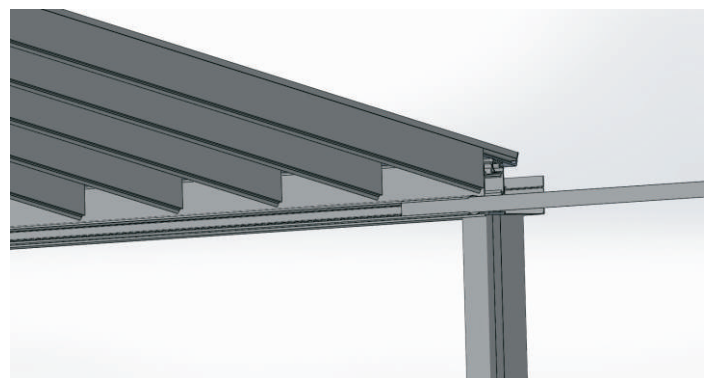
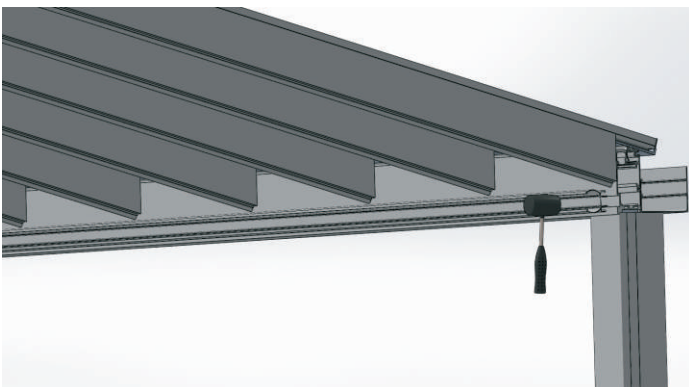

Attaching the lighting to the Alfresco wall plate:

To do this drill a hole through the back of the light channel (facing the wall) in the desired location for cable exit using a 6mm drill bit, crimp the cables to the red and black LED cables exiting the light channel and feed the extended cables through the hole and run them into the building or the plastic external box supplied and connect them to the capacitor. Then slide the polycarbonate lens back into the light and screw the end cap back on to the light channel. The capacitor will then need to be powered to the mains either via a fused spur or a plug socket as per the specification detailed on the lighting capacitor.

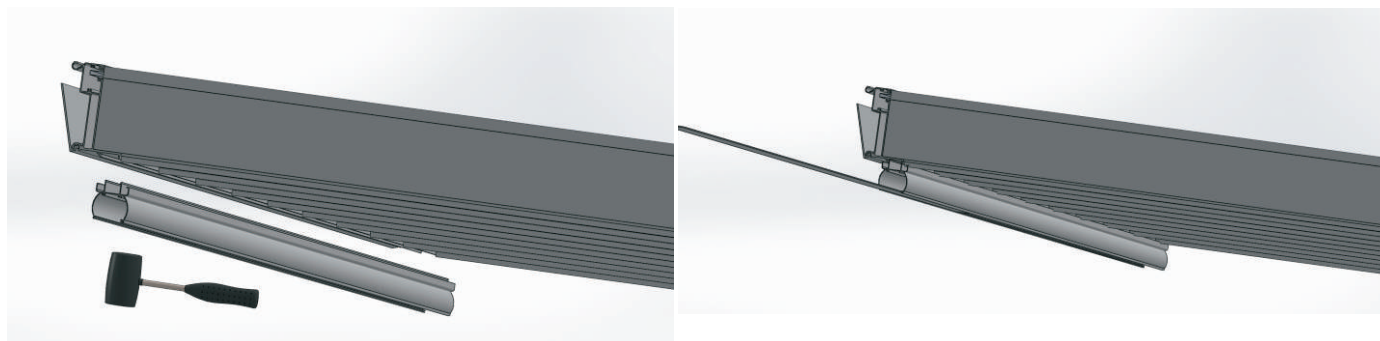

End.

